

**NOTES:**

1. DRIVEWAYS SHALL NOT EXCEED 18' IN WIDTH MEASURED AT THE RIGHT-OF-WAY LINE.
2. DRIVEWAYS SHALL NOT ENCROACH OVER THE PROPERTY LINE EXTENSION IN THE PARKWAY.
3. DRIVEWAYS ARE NOT PERMITTED IN EASEMENTS UNLESS APPROVED BY THE CITY ENGINEER.
4. ALL AGGREGATE SUB-BASE SHALL BE MECHANICALLY COMPACTED.
5. SIDEWALK SHALL CONTINUE THROUGH DRIVEWAYS.
6. SIDEWALKS SHALL FOLLOW CURRENT ADA GUIDELINES .
7. SIDEWALK CONSTRUCTION SHALL FOLLOW APPLICABLE IDOT STANDARDS
8. SIDEWALK THICKNESS ACROSS DRIVEWAYS SHALL BE A MINIMUM OF 6" PCC ON 2" AGGREGATE SUB BASE.
9. SIDE LOAD DRIVEWAYS SHALL BE 14' AT ROW AND 18' AT CURB.
10. DRIVEWAYS SHALL BE CONSTRUCTED ON THE HIGH ELEVATION SIDE OF THE LOT AND FURTHEST FROM THE INTERSECTION.
11. DRIVEWAYS SHALL BE 5' MINIMUM FROM ANY STREETLIGHTS, PEDESTALS, OR FIRE HYDRANTS.

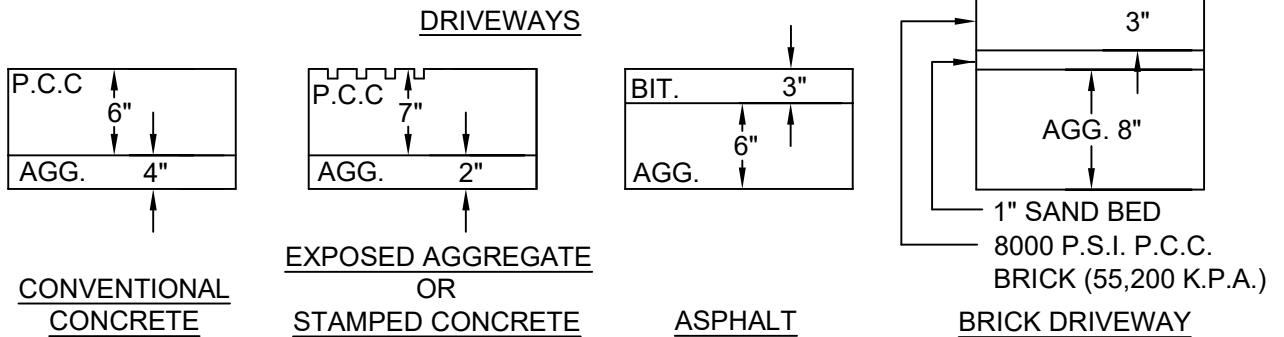
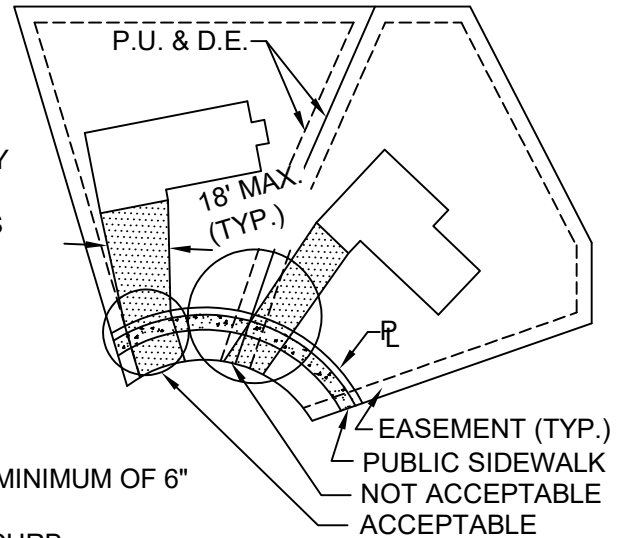

**CITY OF BATAVIA  
PUBLIC WORKS DEPARTMENT**

SHEET: 1 OF 2  
DATE: 6/5/19

**TYPICAL RESIDENTIAL DRIVEWAY**

**STANDARD NO. 7.17**

**MULTIPLE DRIVEWAYS**

F = PROPERTY WIDTH  
AT FRONT PROPERTY  
LINE

W1 = DRIVEWAY WIDTH AT  
PROPERTY LINE

W2 = DRIVEWAY WIDTH AT  
PROPERTY LINE

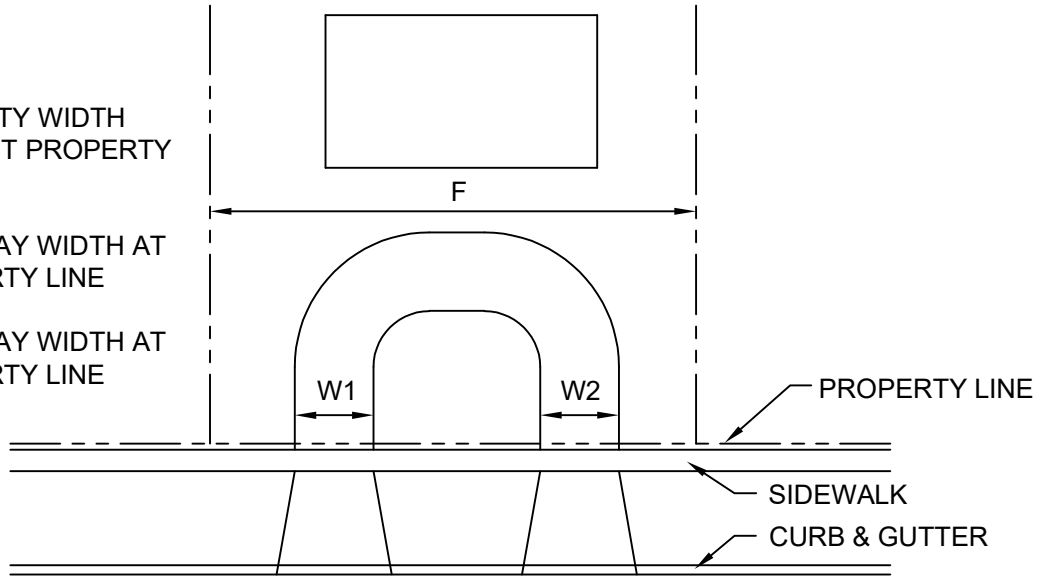

FOR MULTIPLE DRIVEWAYS TO BE PERMITTED, THE FOLLOWING CONDITIONS MUST BE MET:

1. THE PROPERTY WIDTH (F) MUST BE GREATER THAN 75'.
2.  $(F/75)(20) > W1+W2$ , BUT SHALL NOT EXCEED 18' EACH. THIS FORMULA ALSO APPLIES TO CORNER LOTS. DRIVEWAY LOCATIONS FOR CORNER LOTS SHALL COMPLY WITH REQUIREMENTS SET FOR BOTH WIDTH AND LOCATION AS INDICATED BELOW.

**RESIDENTIAL DRIVEWAY NEAR INTERSECTION**

ON THE FAR SIDE OF AN INTERSECTION, THE EDGE OF THE DRIVEWAY AT THE CURB MUST BE AT LEAST 10' FROM THE PROPERTY LINE EXTENDED.

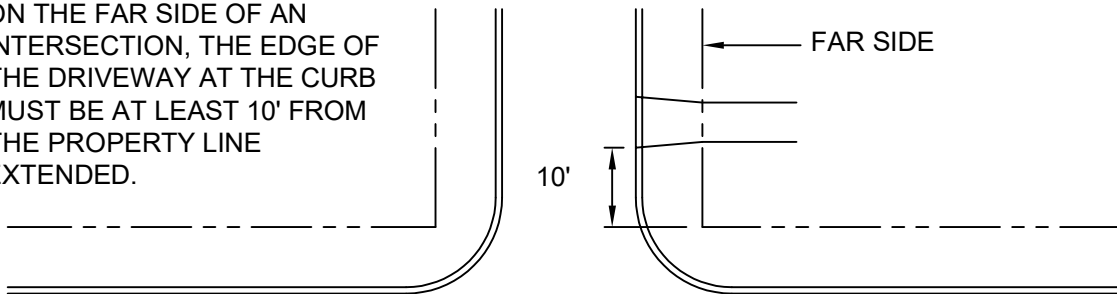

ON THE NEAR SIDE OF AN INTERSECTION, THE EDGE OF THE DRIVEWAY AT THE CURB MUST BE AT LEAST 20' FROM THE PROPERTY LINE EXTENDED.

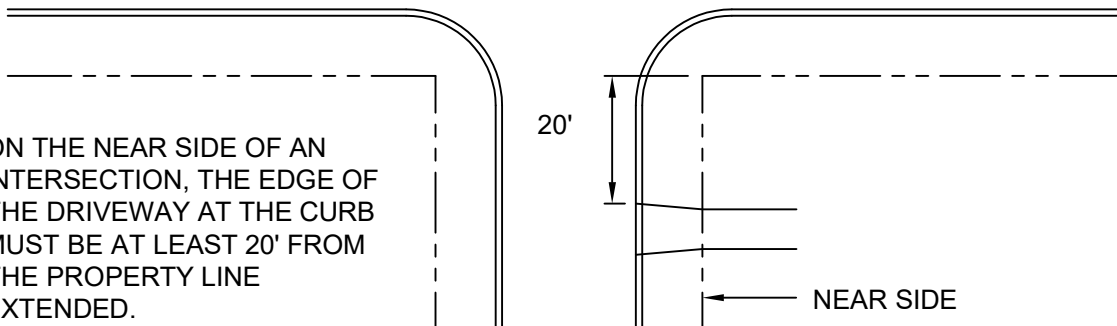

**CITY OF BATAVIA  
PUBLIC WORKS DEPARTMENT**

SHEET: 2 OF 2  
DATE: 6/5/19

**TYPICAL RESIDENTIAL DRIVEWAY**

**STANDARD NO. 7.17**